

Rotary Arm Series Stretch Wrappers

COBRA[®]

1525CN Automatic

High Performance Octo-Thread carriage



Simplified film
threading with
improved operator
ergonomics



Cobra 1525CN with standard infeed, process and exit conveyor. Shown with Deluxe Fencing. Conveyor-Ready Cobra 1525CR also available.

- Wraps up to 40 loads per hour
- Heavy duty construction
- Pre-stretches film up to 300%
- Installs over existing conveyor or can be provided with conveyor
- Positive, non-slip V-belt rotation drive
- Allen-Bradley PLC with operator interface
- Octo-Thread carriage allows easy film threading
- Strain gauge film delivery control
- 3-1/2" dia. conveyor rollers on 3-3/4" centers (1500CN model)

TW Muller

Cobra 1525CN

Automatic Rotary Arm Stretch Wrapper

Specifications

Standard configuration listed below. Please contact your sales representative for other available configurations.

Performance

| | |
|---------------------|---|
| Loads per hour | Up to 40 |
| Rotation speed | 12 rpm (optional to 18 rpm) |
| Maximum load size | 50" x 50" x 80" H (70" dia.) |
| Minimum load size | 36" x 36" x 28" H (film clamp justified) |
| Maximum load weight | 1525CN: 4,800 pounds 1525CR: dependent on conveyor |

Film Delivery System

| | |
|-------------------|--|
| Film capacity | 20" roll width x 10" dia. |
| Pre-stretch type | Strain gauge |
| Pre-stretch level | 250% (optional 100% to 300%) |
| Force control | Variable |
| Film threading | Octo-Thread design; W film threading pattern |
| Cut and seal | Controlled impulse cutter and heat sealer |

Controls

| | |
|-----------------------|--|
| Controller | Allen-Bradley PLC |
| Operator interface | Touch screen |
| Load height sensor | Photo eye |
| Wrap settings | Re-wrap function; overwrap and overlap adjustments |
| Wrap counters | Independent top and bottom |
| Cycle counters | Total cycle counter and resettable counter |
| Emergency stop | Mushroom head |
| Electrical disconnect | Lockable |
| Electrical enclosure | CSA approved |

Power Requirements

| | |
|-----------|---------------------------------|
| Voltage | 480 VAC, 30 amp, 3 phase, 60 Hz |
| Pneumatic | 80 psi, 3 CFM (clean, dry air) |

Rotary Arm

| | |
|--------------|----------------------------|
| Drive system | Dual V-belt drive |
| Bearing type | Dual pillow block bearings |

Structure

| | |
|--------------------|--|
| Machine weight | 1525CN: 7,150 pounds 1525CR: 2,000 pounds |
| Construction | Heavy duty, welded |
| Color | Dark bronze |
| Rotating arm color | Yellow |

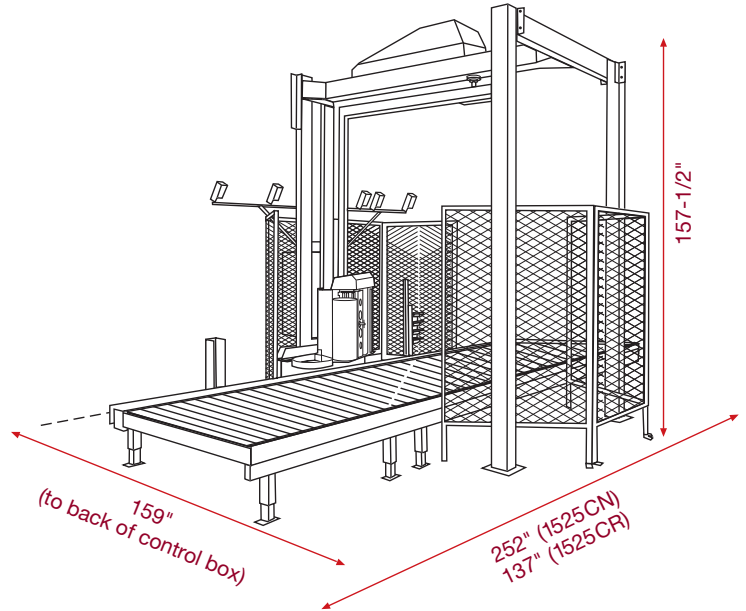

ITW Muller

3456 North Ridge Avenue, Suite 400
Arlington Heights, IL 60004
1-800-OCTOPUS
Fax: 847-483-1500
www.itwmuller.com